



Optical Sensor
Product Data Sheet
LTR-568ALS-01

Spec No. :DS86-2023-0003
Effective Date: 06/26/2024
Revision: -

LITE-ON DCC

RELEASE

BNS-OD-FC001/A4

OPTICAL SENSOR LTR-568ALS-01

Description

The LTR-568ALS-01 is an integrated low voltage I2C ambient light sensor (ALS), and proximity sensor (PS), with built-in emitter in a single miniature chipled lead-free surface mount package.

The ALS provides a linear response over a wide dynamic range, which is well suited to applications under very low or bright ambient brightness. Besides, with built-in proximity sensor, this sensor offers the feature to detect object at a user configurable distance.

The sensor has a programmable interrupt with hysteresis to response to events and that removes the need to poll the sensor for a reading which improves system efficiency. This CMOS design and factory-set one time trimming capability ensure minimal sensor-to-sensor variations for ease of manufacturability to the end customers.

Application

- Control brightness of display panel
- Object detection in mobile, computing, and consumer devices.

Features

- I²C interface (Standard mode @100kHz or Fast mode @400kHz)
- Ambient Light and Proximity Sensing in one ultra-small ChipLED package
- Very low power consumption with sleep mode capability
- Operating voltage ranges: 3.0V to 3.6V
- Operating temperature ranges: -40 to +85 °C
- Built-in temperature compensation circuit
- Programmable interrupt function for ALS and PS with upper and lower thresholds
- RoHS and Halogen free compliant

ALS Features

- 16 bits effective resolution
- Wide dynamic range with linear response
- Close to human eye spectral response
- Automatic rejection for 50Hz/60Hz lighting flicker

PS Features

- Built-in LED driver
- High ambient light suppression
- 16-bit effective resolution
- Cancellation of crosstalk
- Programmable LED drive setting
- Ambient IR saturation indicator

Ordering Information

Part Number	Packaging Type	Package	Quantity
LTR-568ALS-01	Tape and Reel	8-pin chipled package	8000pcs

**OPTICAL SENSOR
LTR-568ALS-01**

1. Outline Dimensions and Pins Configuration

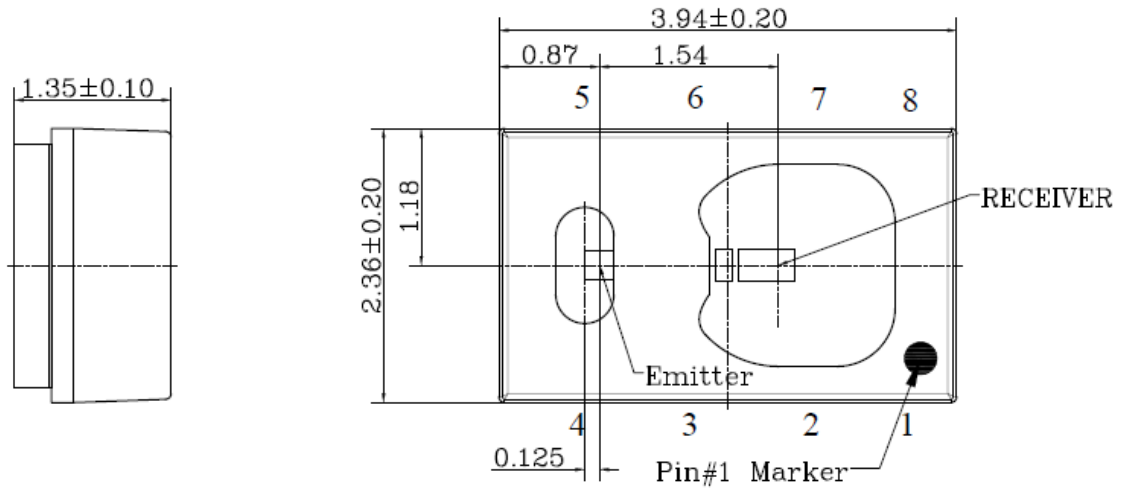

Pin-Out Assignment:

- | | |
|---------|---------|
| 1. SDA | 5. LEDA |
| 2. INT | 6. GND |
| 3. LDR | 7. SCL |
| 4. LEDK | 8. VDD |

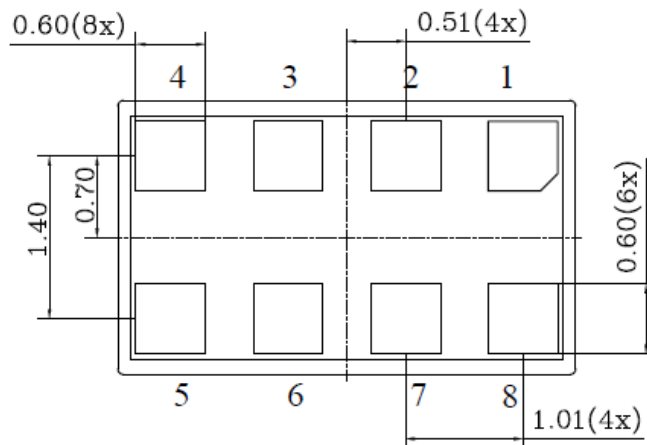
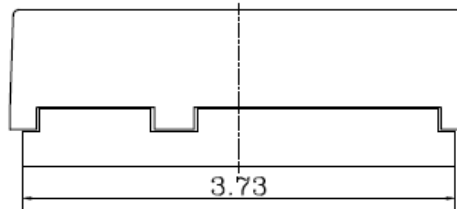

Note: All dimension in millimeter

OPTICAL SENSOR LTR-568ALS-01

2. Functional Block Diagram

The LTR-568ALS-01 contains 2 integrated photodiodes (1 for proximity diode, 1 diodes for ambient diode) for respective photocurrent measurement. The photodiode currents are converted to digital values by ADCs. The sensor also included a LED driver, as well as some peripheral circuits such as an internal oscillator, a current course, voltage reference, and internal fuses to store trimming information.

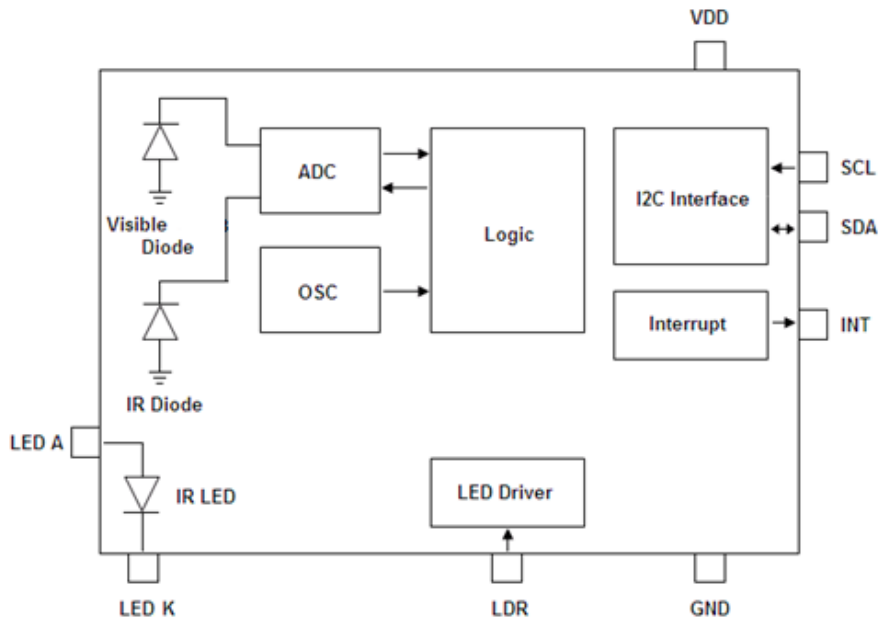

OPTICAL SENSOR LTR-568ALS-01

3. Application Circuit

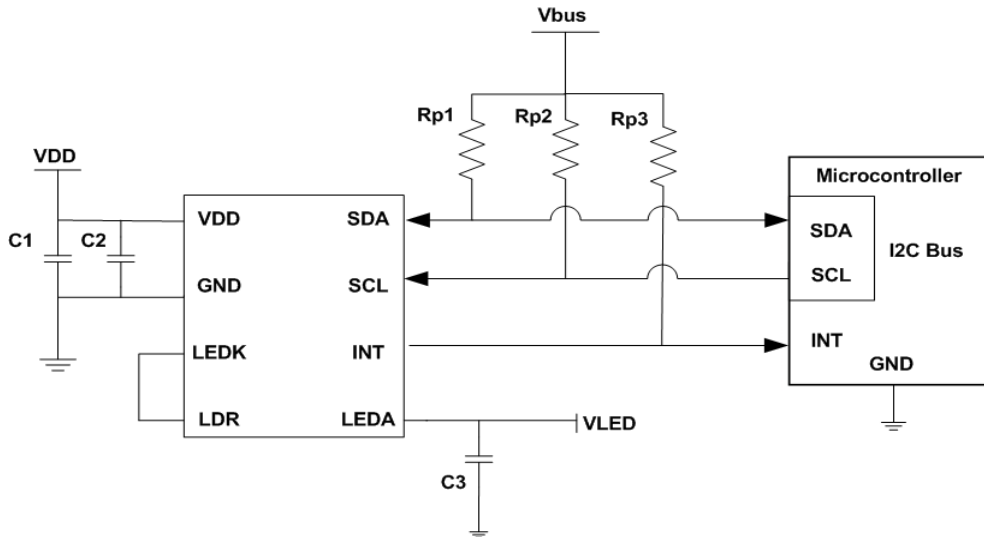

Note: It is a requirement to separate the VDD and VLED

I/O Pins Configuration Table

Pin	I/O Type	Symbol	Description
1	I/O	SDA	I ² C serial data
2	O	INT	Interrupt pin
3	O	LDR	LED driver. To connect to LED Cathode.
4		LDK	LED Cathode. To connect to LED driver
5		LEDA	LED Anode. To connect to VLED
6		GND	GND
7	I	SCL	I ² C serial clock
8		VDD	Supply Voltage

Recommended Application Circuit Components

Component	Recommended Value
Rp1, Rp2, Rp3 [1]	1 kΩ to 10 kΩ
C1, C3	1uF ±20%, X7R / X5R Ceramic
C2,C4	0.1uF

[1] Selection of pull-up resistors value is dependent on bus capacitance values. For more details, please refer to I²C Specifications: http://www.nxp.com/documents/user_manual/UM10204.pdf

OPTICAL SENSOR LTR-568ALS-01

4. Ratings and Specifications

Absolute Maximum Ratings at Ta = 25°C

Parameter	Symbol	Min.	Max	Unit
Supply Voltage	VDD		4.5	V
Digital Voltage Range	SCL, SDA, INT	-0.5	4.5	V
Max Voltage Range	LDR	-0.5	4.5	V
Storage Temperature	T _{stg}	-40	100	°C
Electrostatic Discharge Protection (Human Body Model JESD22-A114)	V _{HBM}		2000	V

Note: Exceeding these ratings could cause damage to the sensor. All voltages are with respect to ground. Currents are positive into, negative out of the specified terminal.

Recommended Operating Conditions

Description	Symbol	Min.	Typ.	Max.	Unit
Supply Voltage	VDD	3.0		3.6	V
LED Supply Voltage	V _{LED}	2.5		4.35	V
Interface signal input high	V _{I2Chigh}	1.5		VDD	V
Interface signal input low	V _{I2Clow}	0		0.4	V
Operating Temperature	T _{ope}	-40		85	°C

Electrical & Optical Specifications

All specifications are at VDD = 3.0V, T_{ope} = 25°C, unless otherwise noted.

Parameter	Min.	Typ.	Max.	Unit	Condition
Supply Current		325		uA	Both ALS and PS Active mode. Default setting
ALS Active Supply Current		325		uA	Full load
PS Active Supply Current		145		uA	Max. MRR with 16pulse 100%duty
Standby Current			5	uA	Shutdown Mode
Wakeup Time from Standby		5	10	ms	From Standby to Active mode where measurement can start

OPTICAL SENSOR LTR-568ALS-01

Characteristics Ambient Light Sensor

Parameter	Min.	Typ.	Max.	Unit	Condition
ALS Resolution			16	Bit	Programmable for 13, 14, 15, 16 Bit
ALS Lux accuracy	-15		15	%	Across different light sources
Dark Level Count			5	Count	0 Lux, 16-bit resolution, gainx128
Integration time	50		400	ms	With 50/60Hz Rejection
50/60 Hz flicker noise error	-5		+5	%	

Characteristics Proximity Sensor

Parameter	Min.	Typ.	Max.	Unit	Condition
PS Resolution			16	Bit	
Sensitivity Range		940		nm	
Detection Distance			8	cm	32us, 7 pulse, 190mA
LED Pulse Current			240	mA	Configurable
LED Pulse width			32	us	Configurable for 4,8,16,32 us
LED Duty Cycle			100	%	
Number of LED Pulses	1		32	Pulses	Programmable from 1 to 32 pulses
Ambient light suppression **			100	klux	Direct sunlight

** Above 50klux, internal fail-safe feature will force PS count to zero to prevent false trigger.

**OPTICAL SENSOR
LTR-568ALS-01**

Typical Device Parameter

(VDD = 2.8V, Ta=25°C, Default power-up settings, unless otherwise noted)

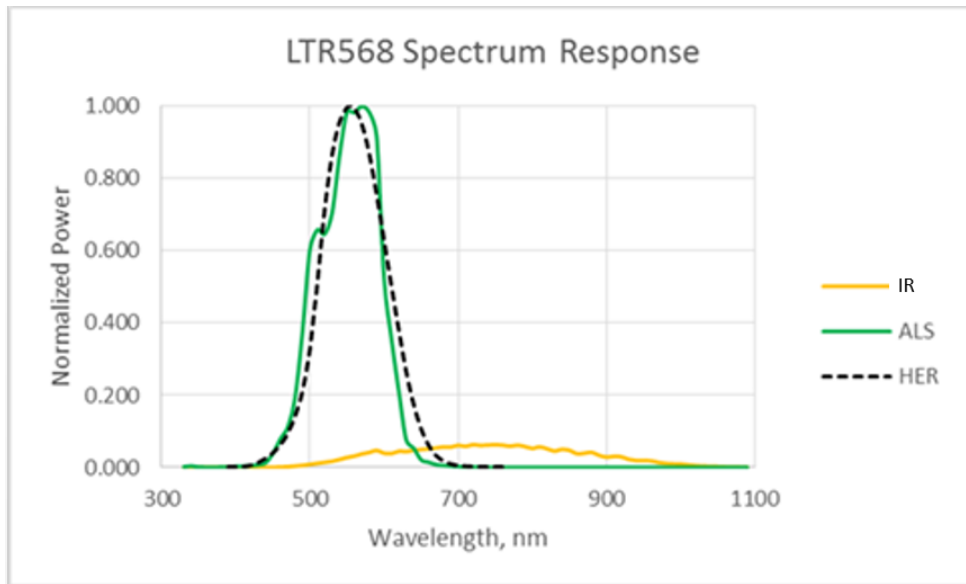

Figure 4.1 : ALS Spectral response

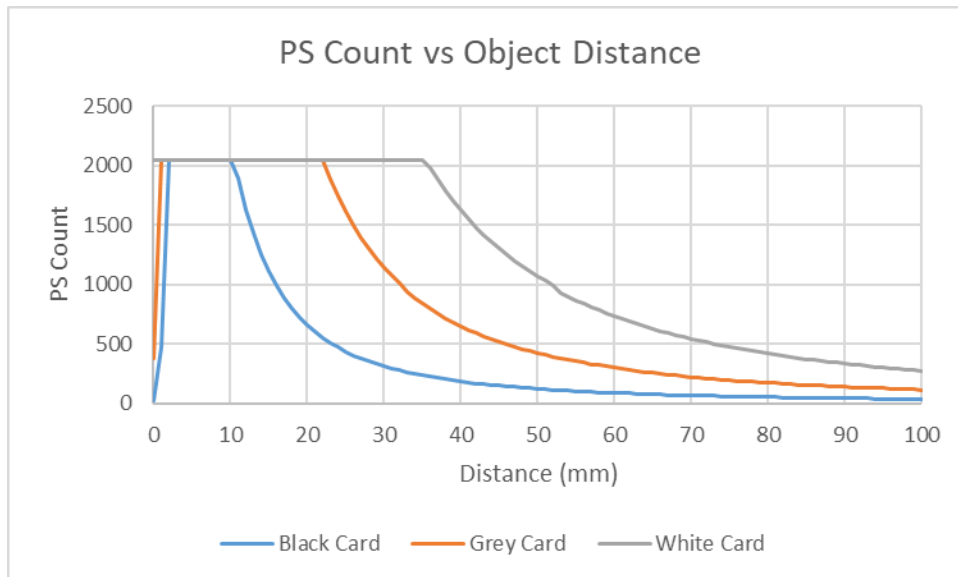

Figure 4.2: PS performance across distance 100mA, 32 pulse, 32us PW, 4x Averaging, Open Air (NO TP).

**OPTICAL SENSOR
LTR-568ALS-01**

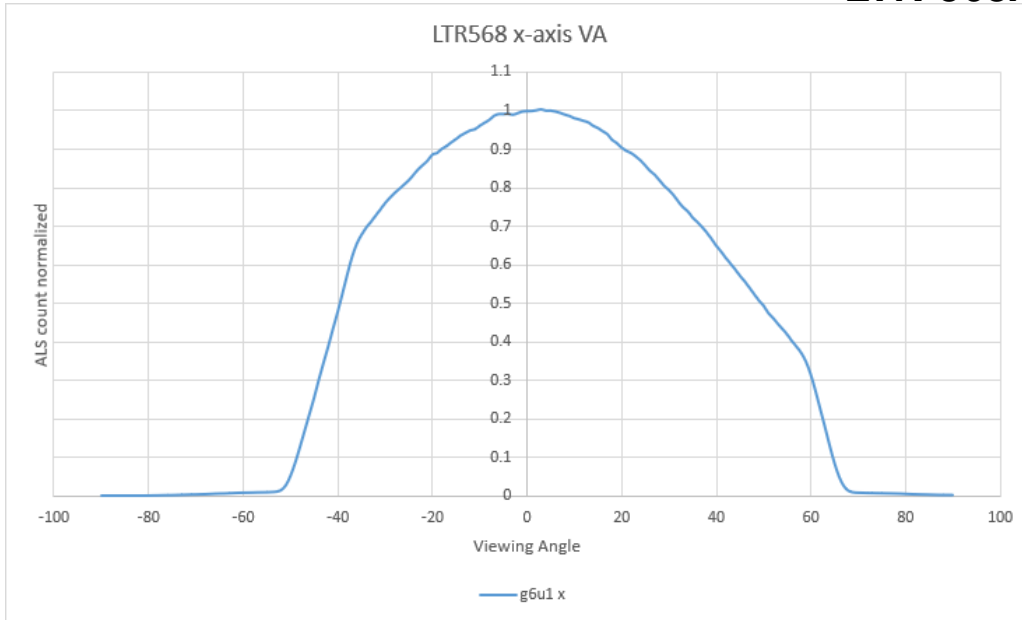

Figure 4.3: ALS viewing angle performance (X-axis)

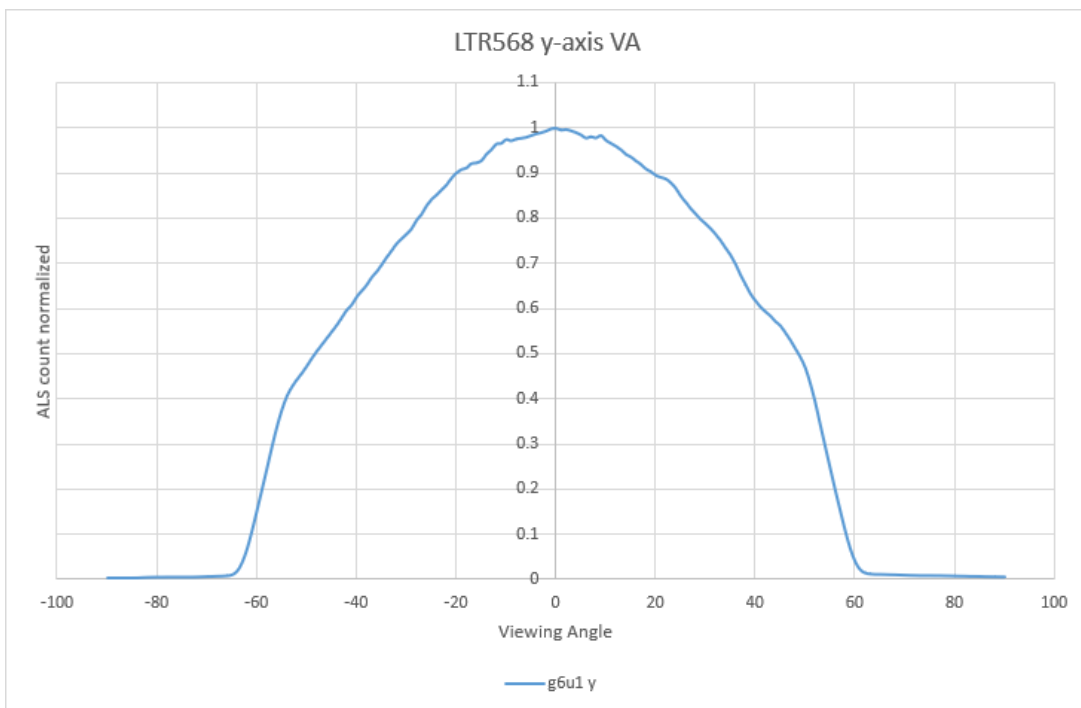

Figure 4.5 ALS viewing angle performance (Y-axis)

OPTICAL SENSOR LTR-568ALS-01

AC Electrical Characteristics

All specifications are at VBus = 1.7V, T_{ope} = 25°C, unless otherwise noted.

Parameter	Symbol	Standard mode		Fast mode		Unit
		Min.	Max.	Min.	Max.	
SCL clock frequency	f_{SCL}	100		400		kHz
Bus free time between a STOP and START condition	t_{BUF}	4.7	-	1.3	-	us
Hold time (repeated) START condition. After this period, the first clock pulse is generated	$t_{HD;STA}$	4.0	-	0.6	-	us
LOW period of the SCL clock	t_{LOW}	4.7	-	1.3	-	us
HIGH period of the SCL clock	t_{HIGH}	4.0	-	0.6	-	us
Set-up time for a repeated START condition	$t_{SU;STA}$	4.7	-	0.6	-	us
Set-up time for STOP condition	$t_{SU;STO}$	4.0	-	0.6	-	us
Rise time of both SDA and SCL signals	t_r	-	1000	-	300	ns
Fall time of both SDA and SCL signals	t_f	-	300	-	300	ns
Data hold time	$t_{HD;DAT}$	0	-	0	-	us
Data setup time	$t_{SU;DAT}$	250	-	100	-	ns

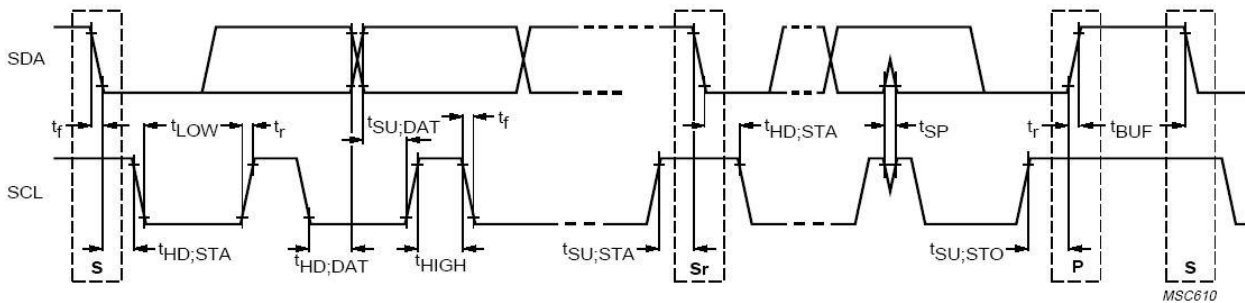

Definition of timing for I²C bus

OPTICAL SENSOR LTR-568ALS-01

5. Principles of Operation

I²C Protocols

• I²C Write Protocol (type 1):

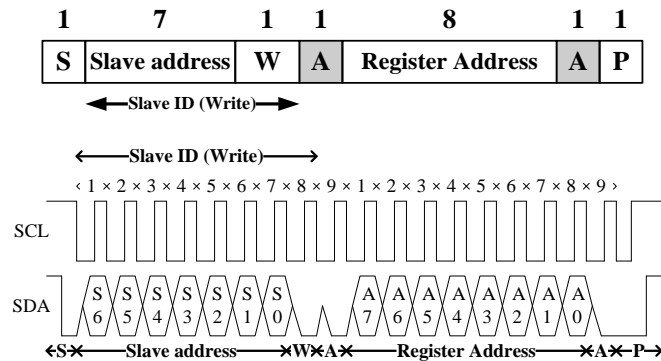

• I²C Write Protocol (type 2):

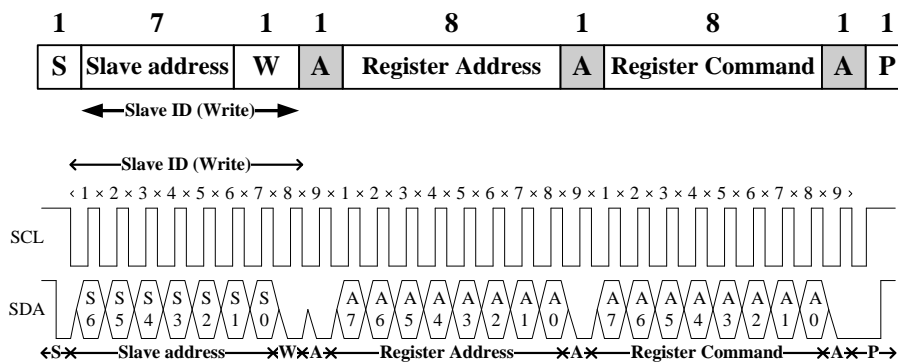

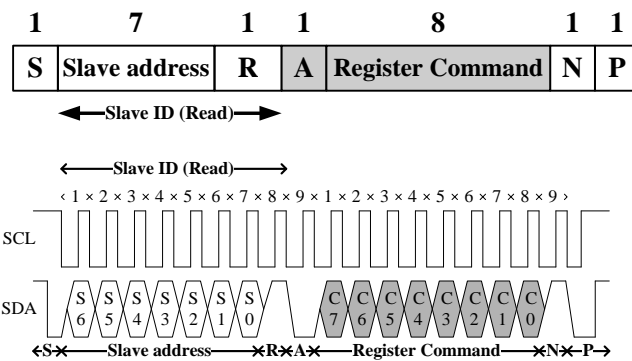

• I²C Read Protocol:

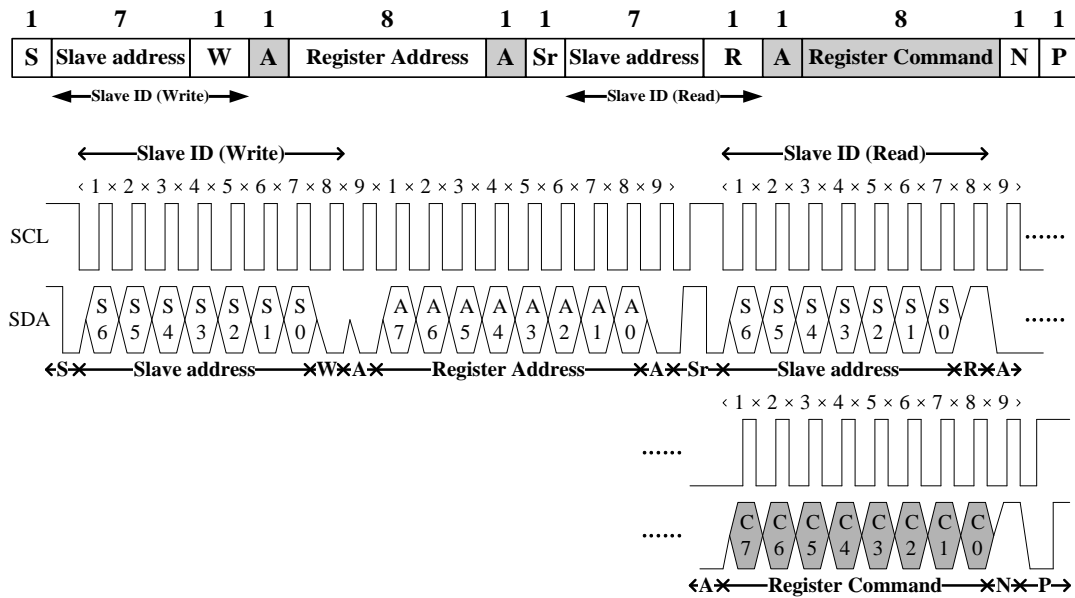

OPTICAL SENSOR LTR-568ALS-01

· I²C Read (Combined format) Protocol:



- | | | | |
|---|----------------------------|---|--------------------------------|
| A | Acknowledge (0 for an ACK) | N | Non-Acknowledge(1 for an NACK) |
| S | Start condition | Sr | Repeated Start condition |
| P | Stop condition | | |
| W | Write (0 for writing) | R | Read (1 for read) |
|  | Slave-to-master |  | Master-to-Slave |

I²C Slave Address

The 7 bits slave address for this sensor is 0x23H. A read/write bit should be appended to the slave address by the master device to properly communicate with the sensor.

I ² C Slave Address									
Command Type	(0x23H)							(0x23H)	(0x23H)
	Bit7	Bit6	Bit5	Bit4	Bit3	Bit2	Bit1	Bit0	
Write	0	1	0	0	0	1	1	0	0x46H
Read	0	1	0	0	0	1	1	1	0x47H

OPTICAL SENSOR LTR-568ALS-01

6. Register Set

Address	R / W	Register Name	Description	Reset Value
0x7E	RW	ALS_AVE_LIMIT	ALS digital averaging limit	0x01
0x7F	RW	ALS_AVE_FAC	ALS digital averaging factor	0x07
0x80	RW	ALS_CONTR	ALS operation mode control	0x20
0x81	RW	PS_CONTR	PS operation mode control/SW Reset	0x10
0x82	RW	PS_LED	PS LED setting	0x7A
0x83	RW	PS_N_PULSES	PS number of pulses	0x00
0x84	RW	PS_MEAS_RATE	PS measurement rate in active mode	0x04
0x85	RW	ALS_INT_TIME	ALS integration time and measurement rate in active mode	0x06
0x86	R	PART_ID	Part Number ID and revision IDs	0x1C
0x87	R	MANUFAC_ID	Manufacturer ID	0x08
0x88	R	ALS_STATUS	ALS Status	0x00
0x89	R	IR_DATA_LSB	ALS/RGB measurement IR data, LSB	0x00
0x8A	R	IR_DATA_MSB	ALS/RGB measurement IR data, MSB	0x00
0x8B	R	GREEN_DATA_LSB	ALS/RGB measurement GREEN data, LSB	0x00
0x8C	R	GREEN_DATA_MSB	ALS/RGB measurement GREEN data, MSB	0x00
0x91	R	PS_STATUS	PS Status	0x08
0x92	R	PS_DATA	PS measurement data, LSB	0x00
0x93	R	PS_DATA	PS measurement data, MSB	0x00
0x98	RW	INTERRUPT	Interrupt settings	0x08
0x99	RW	INTERTUPT_PERSIST	PS and ALS interrupt persist setting	0x00
0x9A	RW	PS_THRES_HIGH_LSB	PS interrupt upper threshold, LSB	0xFF
0x9B	RW	PS_THRES_HIGH_MSB	PS interrupt upper threshold, MSB	0xFF
0x9C	RW	PS_THRES_LOW_LSB	PS interrupt lower threshold, LSB	0x00
0x9D	RW	PS_THRES_LOW_MSB	PS interrupt lower threshold, MSB	0x00
0x9E	RW	PXTALK_LSB	Xtalk correction on PS CH0 PD, LSB	0x00
0x9F	RW	PXTALK_MSB	Xtalk correction on PS CH0 PD, MSB	0x00
0xB6	RW	PS_VREHL	External PS VREHL value, affect PS	0x08

OPTICAL SENSOR LTR-568ALS-01

ALS_AVE_LIMIT Register (0x7E) (Read/Write)

The ALS_AVE_LIMIT register controls ALS digital averaging delta limit (new data – old data).

0x7E	ALS_AVE_LIMIT (default = 0x00)							
	Bit 7	Bit 6	Bit 5	Bit 4	Bit 3	Bit 2	Bit 1	Bit 0
	<i>Reserved</i>						<i>ALS_AVE_LIMIT</i>	

Field	Bits	Default	Description	
Reserved	7:2	000000		
ALS_AVE_LIMIT	1:0	01	00	511
			01	255(default)
			1x	127

ALS_AVE_FAC Register (0x7F) (Read/Write)

The ALS_AVE_FAC register controls ALS digital averaging factor value.

0x7F	ALS_AVE_FAC (default = 0x07)							
	Bit 7	Bit 6	Bit 5	Bit 4	Bit 3	Bit 2	Bit 1	Bit 0
	<i>ALS_AVE_FAC</i>							

Field	Bits	Default	Description	
ALS_AVE_FAC	7:0	00	00000000	No averaging
			00000001	Factor =1
			00000010	Factor = 2
			.	.
		
			00000111	Factor =7 (default)
			.	.
			.	.
			11111111	Factor = 255

OPTICAL SENSOR LTR-568ALS-01

ALS_CONTR Register (0x80) (Read/Write)

The ALS_CONTR register controls the ALS operation modes for the sensor. The ALS sensor can be set to either standby mode or active mode. At either of these modes, the I2C circuitry is always active. The default mode after power up is standby mode. During standby mode, there is no ALS measurement performed but I2C communication is allowed to enable read/write to all the registers.

0x80	ALS_CONTR (default = 0x20)							
	Bit 7	Bit 6	Bit 5	Bit 4	Bit 3	Bit 2	Bit 1	Bit 0
	<i>ALS resolution</i>		<i>IR_EN</i>	<i>ALS_Gain</i>			<i>Reserved</i>	<i>ALS Mode</i>

Field	Bits	Default	Description	
ALS_DR	7:6	00	00	16Bits Integration (default)
			01	15Bits Integration
			10	14Bits Integration
			11	13Bits Integration
IR_EN	5	1	0	Disable
			1	Enable (default)
ALS_GAIN	4:2	000	000	Gain 1X (default) *
			001	Gain 4X
			010	Gain 16X
			011	Gain 64X
			100	Gain 128X
			101	Gain 512X
Reserved	1	0		Reserved
ALS MODE	0	0	0	Stand-by mode (default)
			1	Active mode

OPTICAL SENSOR LTR-568ALS-01

PS_CONTR Register (0x81) (Read/Write)

The PS_CONTR register controls the PS operation modes and software reset for sensor. The PS sensor can be set to either standby mode or active mode. At either of these modes, the I2C circuitry is always active. The default mode after power up is standby mode. During standby mode, there is no ALS measurement performed but I2C communication is allowed to enable read/write to all the registers.

0x81	PS_CONTR (default = 0x10)							
	Bit 7	Bit 6	Bit 5	Bit 4	Bit 3	Bit 2	Bit 1	Bit 0
	Reserved		PS_16BITS_EN	Reserved	PS_OS	FTN/NTF enable	PS Mode	SW Reset

Field	Bits	Default	Description	
Reserved	7:6	00	Must write as 00	
PS_16BITS_EN	5	0	0	Output 11 bits (default)
			1	Output 16 bits
Reserved	4	1	Must write as 1	
PS_OS	3	0	PS Offset/Xtalk Cancellation. When enabled, PS DATA will be subtracted with PS OFFSET register data.	
			0	Disabled (default)
			1	Enabled
FTN/FTN_EN	2	0	0	Disable FTN/NTF Status reporting (default)
			1	Enable FTN/NTF Status reporting
PSMODE	1	0	1	Active Mode
			0	Stand-by mode (default)
SW_RST	0	0	Reset registers to default values, with sensor into standby mode.	
			0	No action (default)
			1	Reset Registers to default values (including calibration values)

OPTICAL SENSOR LTR-568ALS-01

PS_LED Register (0x82) (Read/Write)

The PS_LED register controls the LED pulse width and LED peak current.

0x82	PS_LED (default = 0x7A)							
	Bit 7	Bit 6	Bit 5	Bit 4	Bit 3	Bit 2	Bit 1	Bit 0
	Reserved		PLED pulse duty		PLED Pulse Width		LED current	

Field	Bits	Default	Description	
Reserved	7	0	Must write 0	
PLED Pulse Duty	6:5	11	00	12.5%
			01	25%
			10	50%
			11	100%(default)
PLED Pulse Width	4:3	11	00	4us
			01	8us
			10	16us
			11	32us (default)
LED current	2:0	010	000	0 mA
			001	50 mA
			010	100 mA (default)
			011	120 mA
			100	140 mA
			101	170 mA
			110	190 mA
			111	240 mA

**OPTICAL SENSOR
LTR-568ALS-01**

PS_N_Pulses Register (0x83) (Read/Write)

The PS_N_Pulses register controls the number of PS set of Sequence and LED pulses to be emitted.

0x83	PS_N_Pulses (default = 0x00)							
	Bit 7	Bit 6	Bit 5	Bit 4	Bit 3	Bit 2	Bit 1	Bit 0
	<i>PS averaging factor</i>		<i>Reserved</i>	<i>LED Pulse Count</i>				

Field	Bits	Default	Description	
PS averaging factor	7:6	00	00	No average (default)
			01	2n averaging
			10	4n averaging
			11	8n averaging
Reserved	5	0		Must write 0.
PS number of LED pulses	4:0	00000		Specifies PS LED number of pulses. If PS number of pulse set to 0, the pulse count will be 1.

OPTICAL SENSOR LTR-568ALS-01

PS_MEAS_RATE Register (0x84) (Read/Write)

The ALS_PS_MEAS_RATE register controls the timing of the periodic measurements of the ALS and PS in active mode. Measurement Repeat Rate is the interval between DATA registers update.

0x84	ALS_PS_MEAS_RATE (default = 0x04)							
	Bit 7	Bit 6	Bit 5	Bit 4	Bit 3	Bit 2	Bit 1	Bit 0
	Reserved					PS Measurement Repeat Rate		

Field	Bits	Default	Description	
Reserved	7:3	00000	Must write as 00000	
PS Measurement Rate	2:0	100	000	6.125ms
			001	12.5ms
			010	25ms
			011	50ms
			100	100ms (default)
			101	200ms
			110	400ms
			111	800ms

OPTICAL SENSOR LTR-568ALS-01

ALS_INT_TIME Register (0x85) (Read/Write)

The ALS_MEAS_RATE register controls the integration time and timing of the periodic measurement of the ALS in active mode.

0x85	ALS_INT_TIME (default = 0x06)							
	Bit 7	Bit 6	Bit 5	Bit 4	Bit 3	Bit 2	Bit 1	Bit 0
	Reserved				ALS Integration Time		ALS Measurement Rate	

Field	Bits	Default	Description
Reserved	7:4	000	Must write 1010
ALS Integration Time	3:2	01	00 50msec
			01 100msec (default)
			10 200msec
			11 400msec
ALS measurement rate	1:0	10	00 100msec
			01 200msec
			10 400msec (default)
			11 800msec

PART_ID Register (0x86) (Read Only)

The PART_ID register defines the part number and revision identification of the sensor.

0x86	PART_ID (default = 0x1C)							
	Bit 7	Bit 6	Bit 5	Bit 4	Bit 3	Bit 2	Bit 1	Bit 0
	Part Number ID						Revision ID	

OPTICAL SENSOR LTR-568ALS-01

MANUFAC_ID Register (0x87) (Read Only)

The MANUFAC_ID register defines the manufacturer identification of the sensor.

0x87	MANUFAC_ID (default = 0x08)							
	Bit 7	Bit 6	Bit 5	Bit 4	Bit 3	Bit 2	Bit 1	Bit 0
	<i>Manufacturer ID</i>							

ALS_STATUS Register (0x88) (Read Only)

The ALS_PS_STATUS register stores information about interrupt status as well as ALS data status. New data means data has not been read before. Everytime measurement is done and data is written to the data register, data status bit should be set to logic 1. Everytime the data register is read, data status bit should be set to logic 0.

Interrupt status declares if ALS and PS criteria are met (ALS or PS measured data is outside of preset threshold window set with upper and lower threshold)

0x88	ALS_STATUS (default = 0x00)							
	Bit 7	Bit 6	Bit 5	Bit 4	Bit 3	Bit 2	Bit 1	Bit 0
	<i>Reserved</i>	<i>Valid</i>	<i>ALS_Gain</i>			<i>Reserved</i>	<i>Reserved</i>	<i>ALS Data Status</i>

Field	Bits	Default	Description	
Reserved	7	0	0	Must write 0
ALS Data Valid	6	0	0	ALS Data is Valid (default)
			1	ALS Data is Invalid
ALS Data Gain Range	5:3	0	000	Gain 1X (default)
			001	Gain 4X
			010	Gain 16X
			011	Gain 64X
			100	Gain 128X
			101	Gain 512x
Reserved	2	0		Reserved
Reserved	1	0	Don't care	

**OPTICAL SENSOR
LTR-568ALS-01**

ALS data status	0	0	0	OLD data (data already read), (default)
			1	NEW data (first time data is read)

IR_DATA Register (0x89,0x8A) (Read Only)

ALS measurement results are stored in ALS_DATA registers.

Field	Bits	Default	Description
IR_LSB	0x89	0	IR low byte data, bit 0 is LSB of the 16-bit data
IR_MSB	0x8A	0	IR high byte data, bit 7 is MSB of the 16-bit data

ALS_DATA Register (0x8B,0x8C) (Read Only)

ALS measurement results are stored in ALS_DATA registers.

Field	Bits	Default	Description
ALS_LSB	0x8B	0	ALS low byte data, bit 0 is LSB of the 16-bit data
ALS_MSB	0x8C	0	ALS high byte data, bit 7 is MSB of the 16-bit data

**OPTICAL SENSOR
LTR-568ALS-01**

PS_Status Register (0x91) (Read Only)

0x91	PS_Status (default = 0x91)							
	Bit 7	Bit 6	Bit 5	Bit 4	Bit 3	Bit 2	Bit 1	Bit 0
	Reserved		FTN	NTF	Reserved	Ambient Saturation	PS Interrupt Status	PS Data Status

Field	Bits	Default	Description	
Reserved	7:6	00		Reserved
FTN	5	0	0	No far to near object detected (default)
			1	Far to near object detected
NTF	4	0	0	No near to far object detected (default)
			1	Near to far object detected
Reserved	3	1		Reserved
Ambient Saturation	2	0	0	No ambient saturation
			1	Ambient saturation happens
PS interrupt status	1	0	0	interrupt signal INACTIVE (default)
			1	interrupt signal ACTIVE
PS data status	0	0	0	OLD data (data already read), (default)
			1	NEW data (first time data is read)

PS_DATA Register (0x92 ~ 0x93) (Read Only)

PS measurement results are stored in PS_DATA registers.

Field	Bits	Default	Description
PS_Data LSB	0x92	0	PS measurement data LSB
PS_Data MSB	0x93	0	PS measurement data MSB

OPTICAL SENSOR LTR-568ALS-01

INTERRUPT Register (0x98) (Read/Write)

INTERRUPT register controls the operation of the interrupt pin and functions. The ALS_PS_STATUS register is updated even if interrupt pin is INACTIVE / high-impedance state.

0x98	INTERRUPT (default = 0x08)								
	Bit 7	Bit 6	Bit 5	Bit 4	Bit 3	Bit 2	Bit 1	Bit 0	
	Reserved					Interrupt Polarity	Reserved	Interrupt Mode	

Field	Bits	Default	Description	
Reserved	7:3	00001	Must write as 00001	
Interrupt Polarity	2	0	0	INT pin is considered active when it is a logic 0 (default)
			1	INT pin is considered active when it is a logic 1
Reserved	1	0	Must write as 0	
Interrupt mode	0	0	0	Interrupt pin is INACTIVE / high impedance state (default)
			1	Only PS measurement can trigger interrupt

INTERRUPT PERSIST Register (0x99) (Read/Write)

INTERRUPT PERSIST register sets the N number of times the measurement is out of the threshold range settings before asserting the INTERRUPT pin.

0x99	INTERRUPT PERSIST (default = 0x00)							
	Bit 7	Bit 6	Bit 5	Bit 4	Bit 3	Bit 2	Bit 1	Bit 0
	PS_PERSIST				Reserved			

Field	Bits	Default	Description	
PS_PERSIST	7:4	0	0	Every ALS value out of threshold range (default)
			1	1 consecutive PS values out of threshold range
		
			1111	15 consecutive PS values out of threshold range

OPTICAL SENSOR LTR-568ALS-01

Reserved	3:0	0		Must write as 0000
----------	-----	---	--	--------------------

PS_THRESHOLD Registers (0x9A -0x9D) (Read/Write)

PS_THRESHOLD registers are used to set the upper and lower limit of the absolute interrupt threshold value.

Interrupt functions compare the value in the PS_THRESHOLD registers to measured data value in PS_DATA registers.

The data format for PS_THRESHOLD must be the same as that of PS_DATA registers.

For both high and low threshold, LSB must be written first followed by MSB to ensure whole 16 bits are taken effective simultaneously.

Field	Bits	Default	Description	
PTH_HIGH LSB	0x9A	11111111	--	PS upper interrupt threshold value, LSB
PTH_HIGH MSB	0x9B	11111111	--	PS upper interrupt threshold value, MSB
PTH_LOW LSB	0x9C	00000000	--	PS lower interrupt threshold value, LSB
PTH_LOW MSB	0x9D	00000000	--	PS lower interrupt threshold value, MSB

PS_OFFSET Register (0x9E -0x9F) (Read/Write)

PS OFFSET registers let user define PS crosstalk of the device. All PS data will be subtracted by this **OFFSET** registers.

Field	Bits	Default	Description
PS OFFSET LSB	0x9E	0	PS OFFSET LSB
PS OFFSET MSB	0x9F	0	PS OFFSET MSB

PS_VREHL Register (0xB6) (Read/Write)

This register control the device fail-safe feature under bright sunlight. Value has direct relation to sunlight brightness level. Recommendation is 0x06 which is equivalent to 50kLUX of sunlight.

Field	Bits	Default	Description
Reserved	7:0	0000 1000	Must write as 0000 0110

7. Application Information

7.1 ALS Lux Conversion formula

7.1.1 Lux formula for all Gains

Lux_Calc is the calculated lux reading based on the output ADC from ALS DATA regardless of light sources.

$$Lux_{calc} = \frac{0.336 \times ALS_{DATA}}{(GAIN \times INT)} \times Window\ Factor$$

Where :

1. For device under tinted window with coated-ink of flat transmission rate at 400-600nm wavelength, window factor is to compensate light loss due to the lower transmission rate from the coated-ink.
 - a. WFAC = 1 for NO window / clear window glass.
 - b. WFAC >1 device under tinted window glass. Calibrate under white LED.

2. The Gain factors & Integration time factors:

ALS Gain	GAIN
X1	1
X4	4
X16	16
X64	64
X128	128
X512	512

Integration Time (ms)	INT
50	0.5
100	1
200	2
400	4

OPTICAL SENSOR LTR-568ALS-01

7.2 Operating Mode

Stand-by Mode

The device is by default in stand-by mode after power-up. No measurement activity done in either ALS or PS. I2C communication is allowed to be able to read/write to the registers. The device can be reset from MCU by setting appropriate register control (SW reset). Start-up sequence is exactly the same as that when power-on reset is triggered.

Active Mode

The ALS and PS can simultaneously be in active mode (see Fig 1). Measurement data is expected to be available within a known fixed time (refer to measurement time parameter from ALS and PS specification).

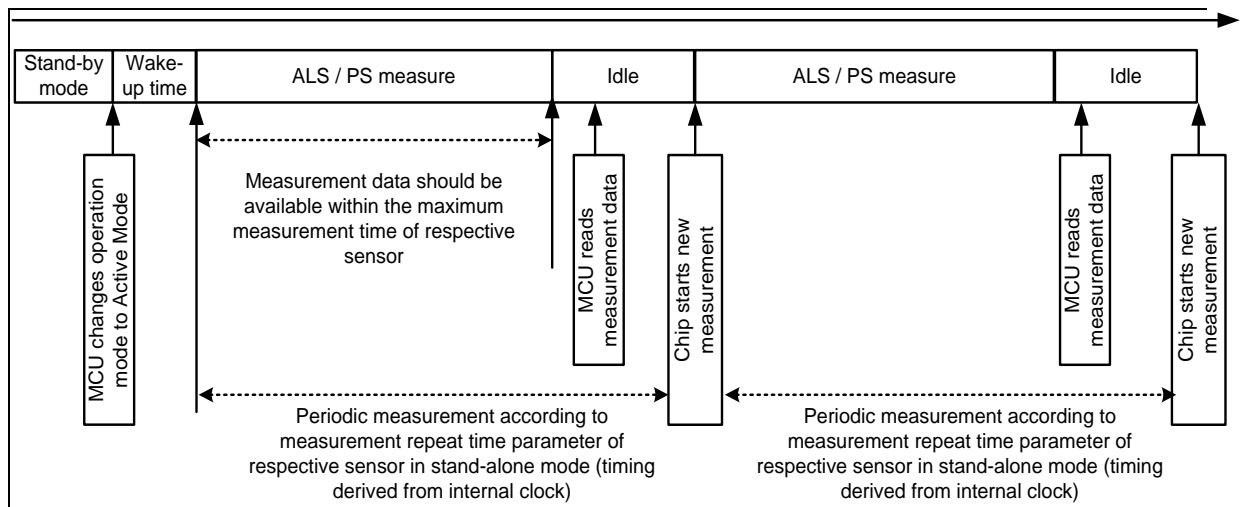

Figure 7.2.1 : ALS and PS measurement sequence

7.3 Interrupt Features

The interrupt function is active if ALS new data is updated OR if PS measurements are outside of the upper and lower absolute threshold levels set in the appropriate threshold register. Only newly measured data is compared to the threshold levels set such that old data will not cause triggering of the INT pin if in case the threshold levels are changed in between measurements.

OPTICAL SENSOR LTR-568ALS-01

The status of interrupt can be monitored directly through the interrupt (INT) pin or by checking contents of the interrupt register. Interrupt pin can either be enable or disabled. Possible to invert interrupt output of LOW or HIGH state.

Interrupt pin IO requirements are exactly the same as those of the I2C bus pins SDA and SCL.

There are two user selectable type of interrupts, which are window interrupt type & logic interrupt type. Refer to Figure 7.3.1 and 7.3.2 for illustration.

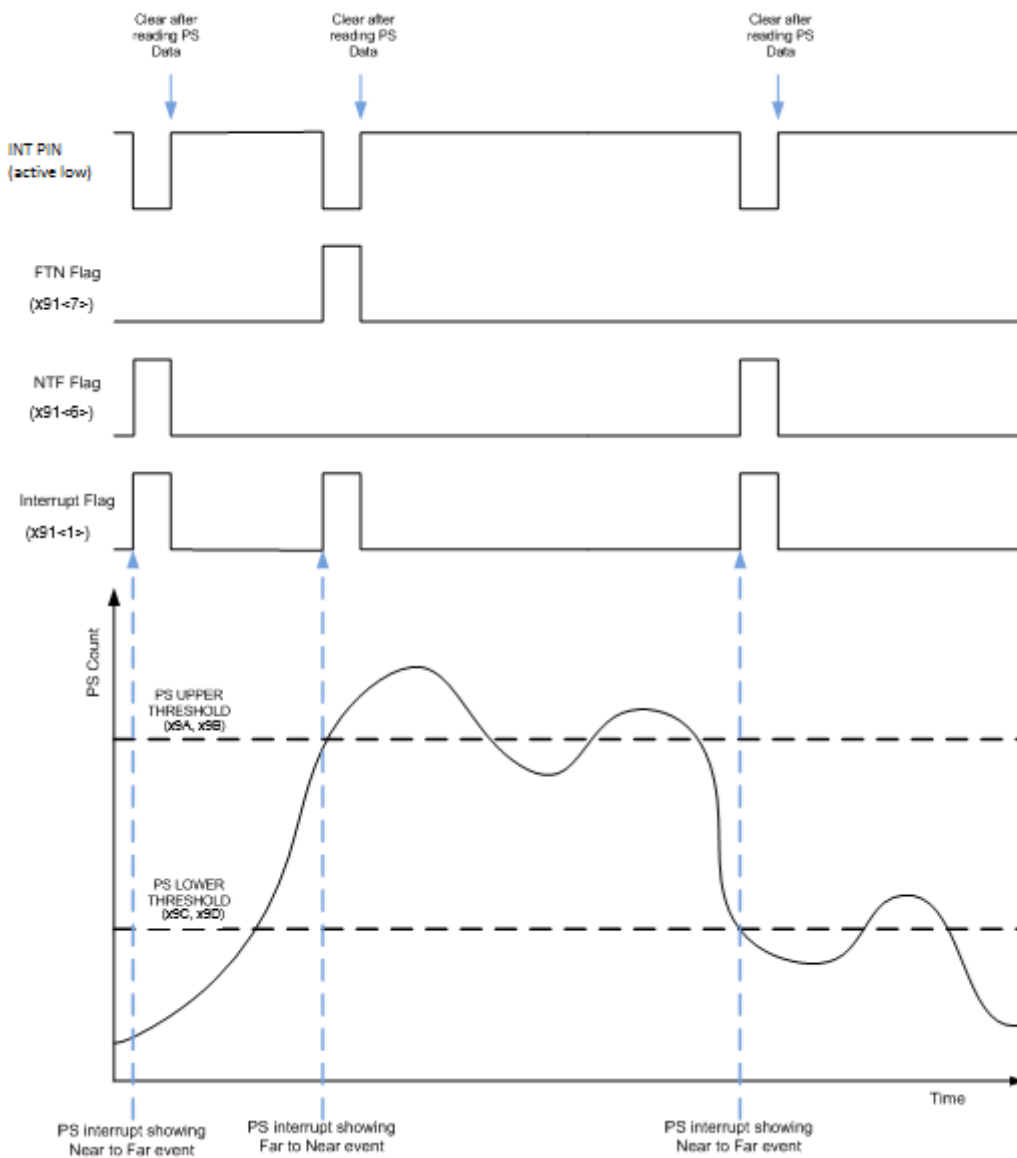

Figure 7.3.1 : Interrupt illustration on logic type (with NTF/FTN reporting)

OPTICAL SENSOR LTR-568ALS-01

(Logic Mode: activated by control register PS_CONTR (0x81<2>) and INTERRUPT (0x91<1>))

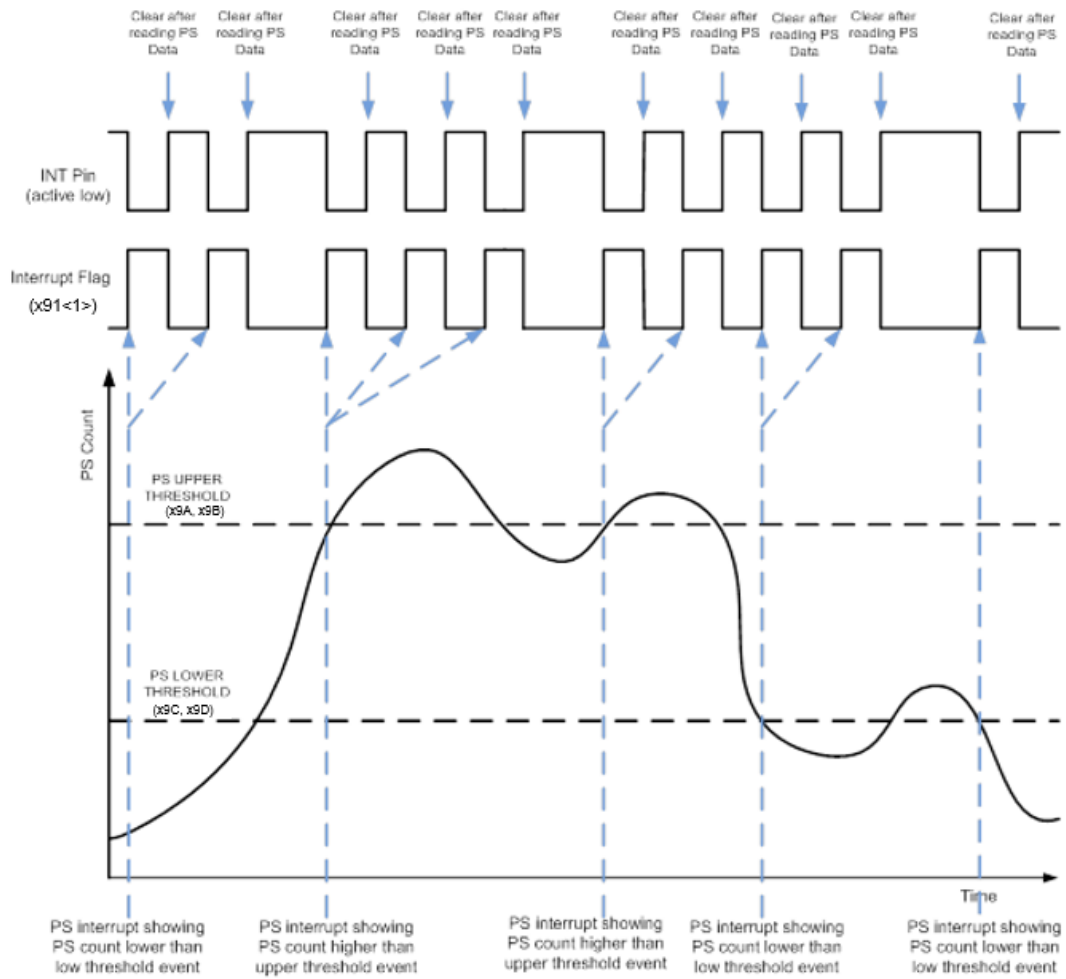
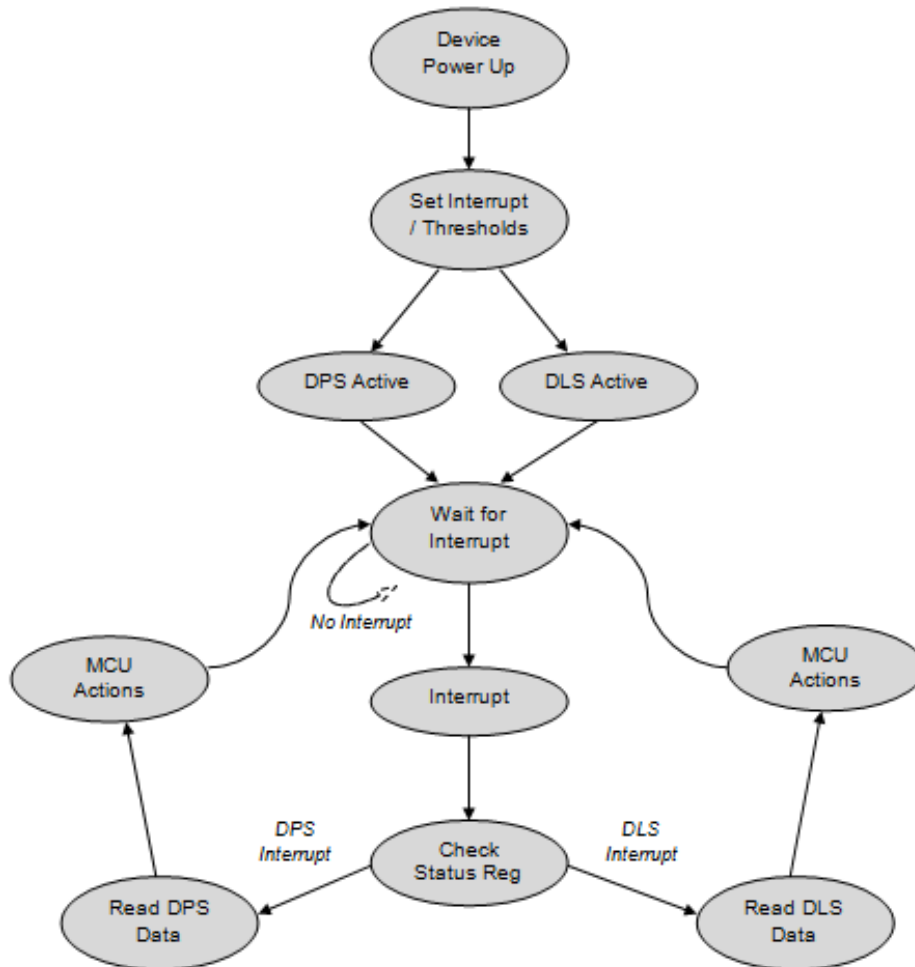

Figure 7.3.2 : Interrupt illustration on window type (by default, without NTF/FTN reporting)

**OPTICAL SENSOR
LTR-568ALS-01**

Flow diagram below illustrates the operation flow, and involving the use of Thresholds and interrupt.



OPTICAL SENSOR LTR-568ALS-01

8. Pseudo Codes Examples

PS LED Registers

// The PS LED Registers define the LED duty, pulse modulation frequency and peak current.

// Default setting is 0x7A (Pulse width 32us, 100mA).

Slave_Addr = 0x23 // Slave address of LTR-568ALS-01 device

// Set LED Pulse width 4us (with default peak current 100mA)

```
Register_Addr = 0x82 // PS_LED register
Command = 0x62 // For Pulse width=4us,Command = 0x62
// For Pulse width = 8us, Command = 0x6A
// For Pulse width = 16us, Command = 0x72
// For Pulse width = 32us, Command = 0x7A
```

WriteByte(Slave_Addr, Register_Addr, Command)

// Set LED Peak Current 0mA (with default pulse width 32us)

```
Register_Addr = 0x82 // PS_LED register
Command = 0x78 // Peak Current = 0mA
// For Peak Current = 50mA, Command = 0x79
// For Peak Current = 100mA, Command = 0x7A
// For Peak Current = 1200mA, Command = 0x7B
// For Peak Current = 140mA, Command = 0x7C
// For Peak Current = 170mA, Command = 0x7D
// For Peak Current = 190mA, Command = 0x7E
// For Peak Current = 240mA, Command = 0x7F
```

WriteByte(Slave_Addr, Register_Addr, Command)

PS_N_Pulses Register

// The PS_N_Pulses register controls the number of PS set of Sequence and LED pulses to be emitted.

// Default setting is 0x00.

Slave_Addr = 0x23 // Slave address of LTR-568ALS-01 device

// Set PS averaging factor 0 (with default number of pulse 1)

```
Register_Addr = 0x83 // PS_N_Pulses register
Command = 0x00 // For PS averaging factor 0, Command = 0x00,
// For PS averaging factor 1, Command = 0x20,
// For PS averaging factor 2, Command = 0x40,
// For PS averaging factor 3, Command = 0x60,
```

// Set LED Pulses to 2 Pulses (with default ps averaging factor 0)

```
Register_Addr = 0x83 // PS_N_Pulses register
Command = 0x01 // For PS pulses = 2,
// For PS pulses = 3, Command = 0x02
// For PS pulses = 4, Command = 0x03
// .....
// For PS pulses = 32, Command = 0x1F
```

WriteByte(Slave_Addr, Register_Addr, Command)

OPTICAL SENSOR LTR-568ALS-01

PS Measurement Rate

// PS_MEAS_RATE register controls the PS measurement rate which define the interval between DATA update.
// Default setting of the register is 0x04

Slave_Addr = 0x23 // Slave address of LTR-568ALS-01 device

// Set PS Repeat Rate 6.125ms

Register_Addr = 0x84 // PS_MEAS_RATE register
Command = 0x00 // Meas rate = 6.125ms
// For Meas rate = 12.5ms, Command = 0x01
// For Meas rate = 25ms, Command = 0x02
// For Meas rate = 50ms, Command = 0x03
// For Meas rate = 100ms, Command = 0x04
// For Meas rate = 200ms, Command = 0x05
// For Meas rate = 400ms, Command = 0x06
// For Meas rate = 800ms, Command = 0x07

WriteByte(Slave_Addr, Register_Addr, Command)

ALS Integration Time

// The ALS_INT_TIME register controls the ALS integration time and ALS measurement rate.
// Default setting of the register is 0x06

Slave_Addr = 0x23 // Slave address of LTR-568ALS-01 device

// Set ALS integration time 50msec (with default ALS measurement rate 400ms)

Register_Addr = 0x85 // ALS_INT_TIME register
Command = 0x02 // Integration time = 50msec
// For Integration time = 100msec, Command = 0x06
// For Integration time = 200msec, Command = 0x0A
// For Integration time = 400msec, Command = 0x0E

// Set ALS measurement rate 100msec (with default ALS integration time 100ms)

Register_Addr = 0x85 // ALS_INT_TIME register
Command = 0x04 // measurement rate = 100msec
// measurement rate = 200msec, Command = 0x05
// measurement rate = 400msec, Command = 0x06
// measurement rate = 800msec, Command = 0x07

WriteByte(Slave_Addr, Register_Addr, Command)

Interrupt Register

// The Interrupt register controls the operation of the interrupt pins and function.
// The default value for this register is 0x08
// The bit7 must be 1.

Slave_Addr = 0x23 // Slave address of LTR-568ALS-01 device

// Set INT pin is considered active when it is a logic 1 (with Interrupt pin is INACTIVE / high impedance state)

Register_Addr = 0x98 // INT pin is considered active when it is a logic 1
Command = 0x8C // INT pin is considered active when it is a logic 1=Command 0x8C
// INT pin is considered active when it is a logic 0=Command 0x88

OPTICAL SENSOR LTR-568ALS-01

```
// Set Only PS measurement can trigger interrupt ( with INT pin is considered active when it is a logic 0)
Register_Addr = 0x98 // Only PS measurement can trigger interrupt
Command = 0x89 // Only PS measurement can trigger interrupt =Command 0x89
// Interrupt pin is INACTIVE / high impedance state =Command 0x88
```

```
WriteByte(Slave_Addr, Register_Addr, Command)
```

Interrupt Persist Register

```
// The Interrupt persist register controls the N number of times the measurement is out of the threshold range settings before
asserting the INTERRUPT pin
// The default value for this register is 0x00
```

```
Slave_Addr = 0x23 // Slave address of LTR-568ALS-01 device
```

// Set 1 consecutive PS values out of threshold range

```
Register_Addr = 0x99 // 1 consecutive PS values out of threshold range
Command = 0x10 // Every PS value out of threshold range =Command 0x00
// 1 consecutive PS values out of threshold range =Command 0x10
// 2 consecutive PS values out of threshold range =Command 0x20
// ....
// 15 consecutive PS values out of threshold range =Command 0xF0
```

```
WriteByte(Slave_Addr, Register_Addr, Command)
```

PS Threshold Registers

```
// The PS_THRES_UP and PS_THRES_LOW registers determines the upper and lower limit of the interrupt threshold
// value.
// Following example illustrates the setting of the PS threshold window of decimal values of 200 (lower threshold) and
// 1000 (upper threshold).
```

```
Slave_Addr = 0x23 // Slave address of LTR-568ALS-01 device
```

// Upper Threshold Setting (decimal 1000)

```
PS_THRES_UP_0 = 0xA8 // PS Upper Threshold Low Byte Register address
PS_THRES_UP_1 = 0xA9 // PS Upper Threshold High Byte Register address
Data1 = 1000 >> 8 // To convert decimal 1000 into two eight bytes register values
Data0 = 1000 & 0xFF
WriteByte(Slave_Addr, PS_Upp_Threshold_Reg_0, Data0)
WriteByte(Slave_Addr, PS_Upp_Threshold_Reg_1, Data1)
```

// Lower Threshold Setting (decimal 200)

```
PS_THRES_LOW_0 = 0xAA // PS Lower Threshold Low Byte Register address
PS_THRES_LOW_1 = 0xAB // PS Lower Threshold High Byte Register address
Data1 = 200 >> 8 // To convert decimal 200 into two eight bytes register values
Data0 = 200 & 0xFF
WriteByte(Slave_Addr, PS_Low_Threshold_Reg_0, Data0)
WriteByte(Slave_Addr, PS_Low_Threshold_Reg_1, Data1)
```

OPTICAL SENSOR LTR-568ALS-01

PS OFFSET Registers

// PS OFFSET registers let user define PS crosstalk of the device. All PS data will be subtracted by this OFFSET registers.
// Following example illustrates the setting of the PS OFFSET of decimal values of 200

Slave_Addr = 0x23 // Slave address of LTR-568ALS-01 device

// PS OFFSET Setting (decimal 200)

PS_OFFSET_0 = 0x9E // PS_OFFSET Low Byte Register address
PS_OFFSET_1 = 0x9F // PS_OFFSET High Byte Register address
Data1 = 200 >> 8 // To convert decimal 200 into two eight bytes register values
Data0 = 200 & 0xFF
WriteByte(Slave_Addr, PS_OFFSET_0, Data0)
WriteByte(Slave_Addr, PS_OFFSET_1, Data1)

PS VREHL Register

// This register need to be written 0x05. Default value is 0x08

Slave_Addr = 0x23 // Slave address of LTR-568ALS-01 device
Command = 0x05

WriteByte(Slave_Addr, PS_VREHL, Command)

Control Registers

// The Control Registers define the operating modes and gain settings of the ALS and PS of LTR-568ALS-01.
// It is recommended that Control Register for ALS (0x80) and PS (0x81) to be set at the end of the sequence.
// This is to ensure all register settings are the same for all started measurement.
// Default settings are 0x20 for ALS register and 0x10 for PS register (both in Standby mode after power up).

Slave_Addr = 0x23 // Slave address of LTR-568ALS-01 device

// Enable ALS

Register_Addr = 0x80 // ALS_CONTR register
Command = 0x21 // For Dynamic Range x1
// For Dynamic Range x4, Command = 0x25
// For Dynamic Range x16, Command = 0x29
// For Dynamic Range x64, Command = 0x2D
// For Dynamic Range x128, Command = 0x31
// For Dynamic Range x512, Command = 0x35

WriteByte(Slave_Addr, Register_Addr, Command)

// Enable PS

Register_Addr = 0x81 // PS_CONTR register
Command = 0x12 // For PS active

// Enable PS OFFSET

Register_Addr = 0x81 // PS_CONTR register
Command = 0x1A // For PS active & enable PS OFFSET

OPTICAL SENSOR LTR-568ALS-01

// Enable FTN/NTF

Register_Addr = 0x81 // PS_CONTR register
Command = 0x1E // For PS active & enable FTN/NTF

WriteByte(Slave_Addr, Register_Addr, Command)

Data Registers (Read Only)

// The ALS and PS Data Registers contain the ADC output data.
// These registers should be read as a group, with the lower address being read first.

Slave_Addr = 0x23 // Slave address of LTR-568ALS-01 device

// Read ALS_DATA

Register_Addr = 0x8B // ALS ADC low byte address
ReadByte(Slave_Addr, Register_Addr, Data0)
Register_Addr = 0x8C // ALS ADC high byte address
ReadByte(Slave_Addr, Register_Addr, Data1)

ALS_ADC_Data = (Data1 << 8) | Data0 // Combining lower and upper bytes to give 16-bit ALS ADC data
(Direct conversion to illuminance in lux).

Slave_Addr = 0x23 // Slave address of LTR-568ALS-01 device

// Read PS_DATA

Register_Addr = 0x92 // PS_DATA low byte address
ReadByte(Slave_Addr, Register_Addr, Data0)
Register_Addr = 0x93 // PS_DATA high byte address
ReadByte(Slave_Addr, Register_Addr, Data1)

PS_ADC_Data = ((Data1 << 8) | Data0) // Combining lower and upper bytes to give 16-bit PS data

ALS Status Register (Read Only)

// The ALS_STATUS Register contains the information on Interrupt, ALS data gain, validity and status.

Slave_Addr = 0x23 // Slave address of LTR-568ALS-01 device

Register_Addr = 0x88 // ALS_STATUS register address
ReadByte(Slave_Addr, Register_Addr, Data)

ALS valid = Data & 0x40 // ALS data valid = 0x80 → ALS data is invalid
// ALS data valid = 0x00 → ALS data is valid

ALS Gain Range = Data & 0x38 // Gain Range = 0x00 → Gain x1
// Gain Range = 0x08 → Gain x4
// Gain Range = 0x10 → Gain x16
// Gain Range = 0x18 → Gain x64
// Gain Range = 0x20 → Gain x128
// Gain Range = 0x28 → Gain x512

ALS Data_Status = Data & 0x01 // NewData_Status = 0x00 → OLD data
// NewData_Status = 0x01 → NEW data

OPTICAL SENSOR LTR-568ALS-01

PS Status Register (Read Only)

// The PS_STATUS Register contains the information on Interrupt, NTF/FTN information, ambient saturation and PS status.

Slave_Addr = 0x23 // Slave address of LTR-568ALS-01 device

Register_Addr = 0x91 // PS_STATUS register address
ReadByte(Slave_Addr, Register_Addr, Data)

FTN = Data & 0x20 // FTN = 0x20 → FTN detected
// FTN = 0x00 → No FTN detected
NTF = Data & 0x10 // NTF = 0x10 → NTF detected
// NTF = 0x00 → No NTF detected

Ambient Saturation= Data & 0x04 // Ambient Saturation = 0x04 → Ambient Saturation happens
// Ambient Saturation = 0x00 → No ambient Saturation

PS_Interrupt_Status = Data & 0x02 // Interrupt_Status = 0x02 → PS interrupt is triggered
// Interrupt_Status = 0x00 → PS interrupt is not triggered

PS Data_Status = Data & 0x01 // NewData_Status = 0x00 → OLD data
// NewData_Status = 0x01 → NEW data

OPTICAL SENSOR LTR-568ALS-01

9. Recommended Leadfree Reflow Profile

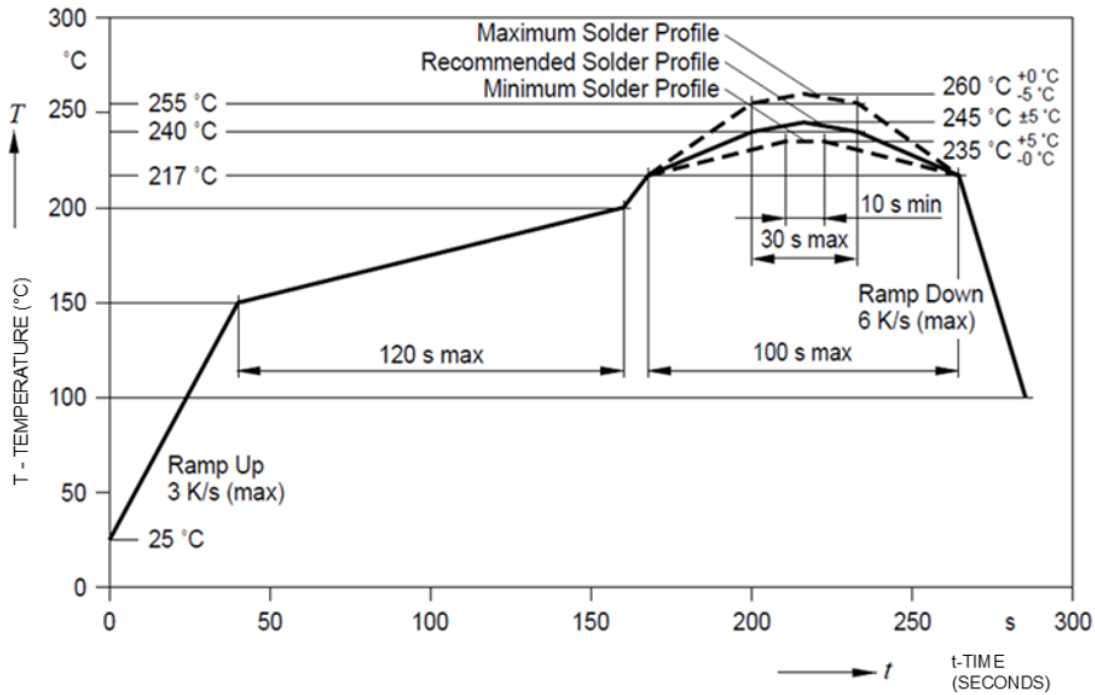

Process Zone	ΔT	Maximum $\Delta T/\Delta \text{time}$ or Duration
Heat Up	25°C to 150°C	3°C/s
Solder Paste Dry	150°C to 200°C	120s max
Solder Reflow	200°C to 245°C	3°C/s
	245°C to 217°C	-6°C/s
Cool Down	217°C to 100°C	-6°C/s
Time maintained above liquidus point , 217°C	> 217°C	100s max
Peak Temperature	245°C	±5°C
Time within 5°C of actual Peak Temperature	> 240°C	10 ~ 20s
Time 25°C to Peak Temperature	25°C to 245°C	8mins max

Notes:

The reflow profile shown in Figure can be a typical range for the customer peak reflow temperature (T_p) of 235°C ~ 250°C to be used.

The peak reflow temperature (T_p) has to be lower than maximum peak reflow temperature (T_p) 260°C shown in Figure. The reflow profile and peak temperature should conform to the solder paste manufacturer recommendation.

It is recommended to perform reflow soldering no more than twice.

**OPTICAL SENSOR
LTR-568ALS-01**

10. Reliability test condition

Classification	Test Item	Test Condition
Pre-con MSL 3 classification test	Preconditioning	Baking in Oven Temp=125°C, Time=24hrs Soak in 60°C, 60%RH, Time=40hrs IR Reflow: Pb free, 3cycles 25°C-150°C, the ramp rate is 3°C/s max 150°C-200°C, the time is 120s max 217°C to peak temperature, the ramp rate is 3°C/s max Time maintained above liquidus point, 217°C is 100s max Peak temperature range 245°C±5°C Time within 5°C of peak temperature time : 10s-20s Peak temperature to 217°C, the ramp-down rate is 6°C/s 217°C --100°C, the ramp-down rate is 6°C /s 25°C to peak temperature, the time is 8mins max TC (-55°C to 105°C) 5cycles
Endurance Test	High Temperature Operation Life (HTOL)	Ta =85°C±5°C Vcc Max=Vdd=3.6V Test Time=500hrs
	Low Temperature Operation Life (LTOL)	Temp=-40°C Vcc Max=Vdd=3.6V Test Time=500hrs
	Temperature Humidity Operation Life (WHTOL)	Temp=65°C Humidity90%RH Vcc Max=Vdd=3.6V Test Time=500hrs
Environmental Test	Temperature Humidity Storage (WHTSL)	Ta =85°C±5°C Humidity= 85%RH Test Time= 168hrs
	Temperature Cycling (TC)	Temp=-55°C to 105°C 30mins/5mins/30mins transfer Test Time=500 cycle

**OPTICAL SENSOR
LTR-568ALS-01**

11. Moisture Proof Packaging

All LTR-568ALS-01 are shipped in moisture proof package. Once opened, moisture absorption begins. This part is compliant to JEDEC J-STD-033 Level 3.

11.1 Shelf Life

Device has the shelf life of 12 months if stored in an unopened moisture proof package. It is recommended to store in following condition.

- Shelf Life : 12 months
- Ambient Temperature : <40°C
- Relative Humidity: <90%

11.2 Floor Life

After removal from the moisture barrier bag, the parts should be stored at the recommended storage conditions and soldered within seven days.

- Floor Life : 168 hours
- Ambient Temperature : <30°C
- Relative Humidity: <60%

11.3 Rebaking information

When the moisture barrier bag is opened and the parts are exposed to the recommended storage conditions for more than seven days, the parts must be baked before reflow to prevent damage to the parts.

Baking Conditions

Package	Temperature	Time
In Reels	60°C	48 hours
In Bulk	100°C	4 hours

Baking should only be done once.

**OPTICAL SENSOR
LTR-568ALS-01**

12. Recommended Land Pattern and Metal Stencil Aperture

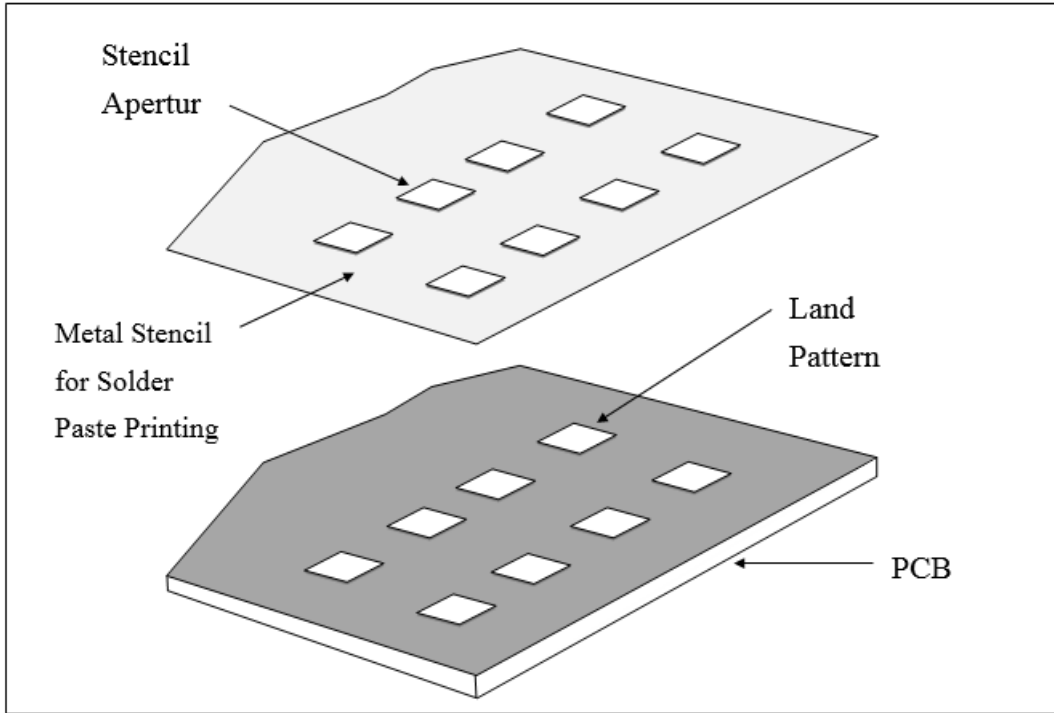

Recommended Land Pattern

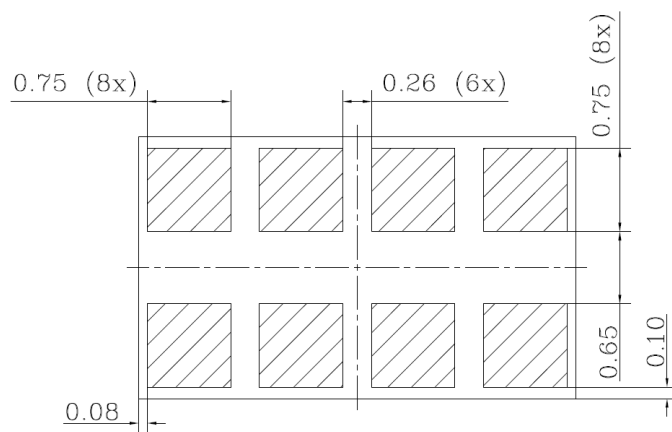

Note: All dimensions are in millimeters

**OPTICAL SENSOR
LTR-568ALS-01**

13.Package Dimension for Tape and Reel

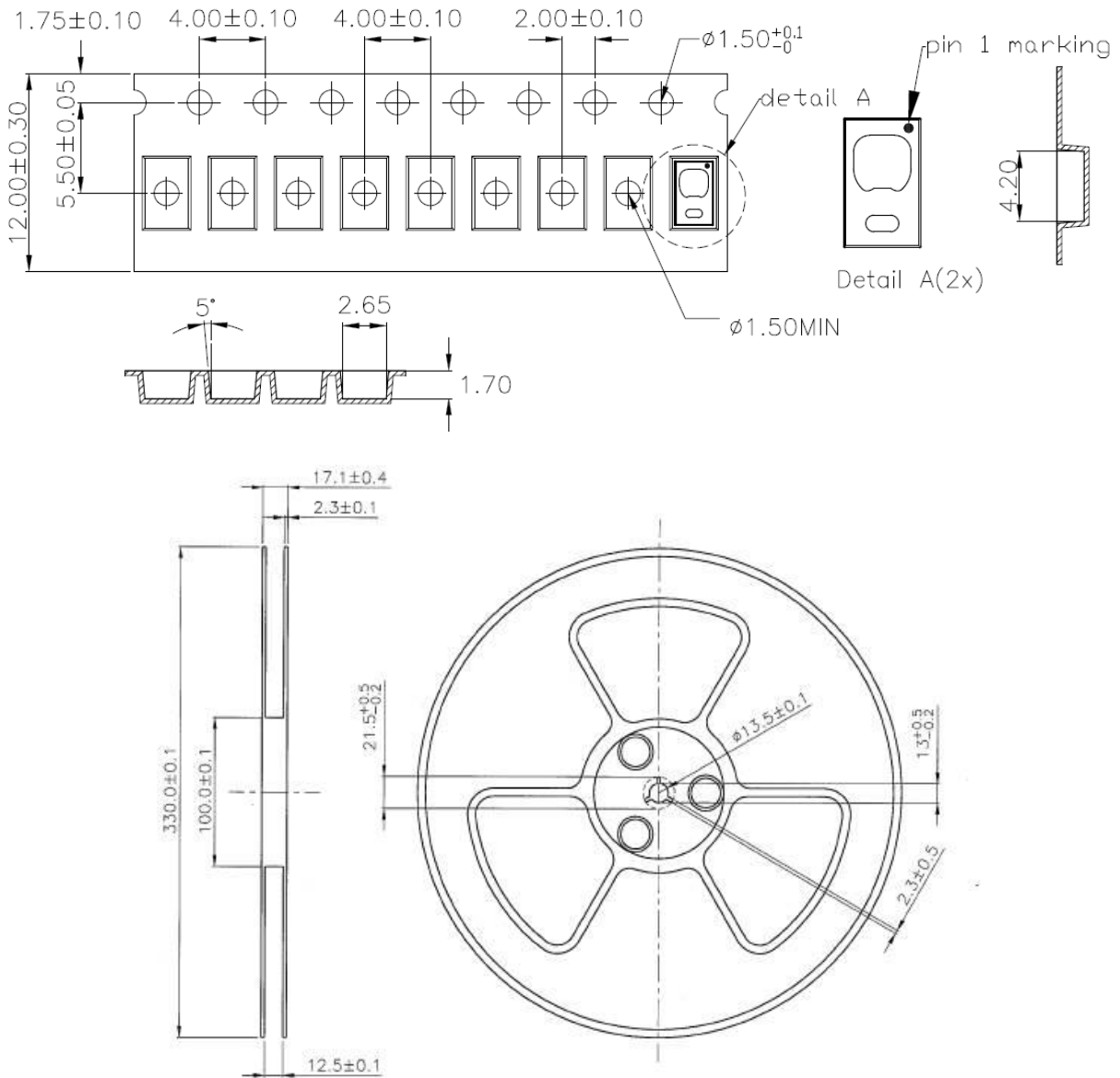

Notes:

1. All dimensions are in millimeters
2. Empty component pockets sealed with top cover tape
3. 13 inch reel - 8000 pieces per reel
4. In accordance with ANSI/EIA 481-1-A-1994 specifications

**OPTICAL SENSOR
LTR-568ALS-01**

Revision Table:

Version	Update	Page	Date
1.0	Datasheet as created	Total 41	20/03/23
1.1	Datasheet update	Total 41	19/04/23
1.2	Updated the minimum voltage	Total 41	25/05/23